

Question: How to program the proper tool path?

Answer:

The burr size and burr location change depending on the rotation & travel of the cutting tool while face milling. In this example, either path A or B works well because you are lifting the burr which improves removal. For example the edges in pink have been rolled over by the face mill while other edges may have a much smaller burr to remove.

CUTTING PROCESS

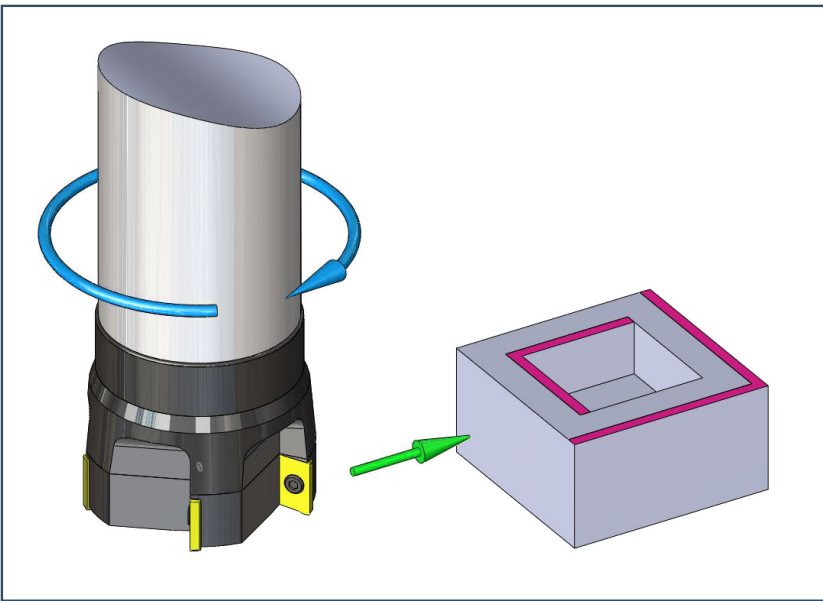

Bigger burrs on the edges in **pink**

CLIMB MILLING TOWARD BIGGER BURR

Path A



Path B

