

XEBEC Floating Holder Instruction Manual (FH-ST20-60, FH-ST20-100)

Read this instruction manual before using this product. Failure to do so can result in serious injury or death. This instruction manual must be kept in the vicinity of the machine at all times so that it is accessible to the operator.

Features

- The built-in spring makes the tool holding tube float, and this allows stable processing via load control with the machine tool.
- It can be used on machining centers, NC lathes, drilling machines, special machines, and other machine tools.
- It is possible to change the cutting load according to the processing quality required.
- Edge quality stabilized by offsetting changes in the cutting amount caused by tool wear.
- Reduces frequency of adjustments required to compensate for changes to depth of cut and bristle length.
- Reduces tool wear by stabilizing processing conditions.

This document may also be viewed at the below website:
https://www.xebec-tech.com/instruction_manual/



- This product is an optional tool designed exclusively for XEBEC Brush Surface. (FH-ST20-60: $\phi 60$, FH-ST20-100: $\phi 100$)
- Do not attach a tool other than the XEBEC Brush Surface.
- Also read the XEBEC Brush Surface Instruction Manual.

SAFETY PRECAUTIONS

Be sure to observe the methods described in this manual.

Using the product in ways inconsistent with the methods described in this manual may result in serious injury or death.

⚠ WARNING

- There is the risk of operator loss of sight or injury resulting from this product detaching from the machining equipments, bristles breaking off, workpieces breaking, etc.
- Fragments, cutting particles, burrs, etc., occur due to processing with this product, and these can pierce the eyes or skin of operators causing loss of sight and injury.
- Dust occurring as a result of processing with this product can cause lung damage, irritate skin, and bring on allergic reactions.
- Even if there is no problem at the pre-work check, if vibration or other abnormality occurs during use, discontinue use immediately. Continuing to use the product when there is an abnormality presents the risk of operator loss of sight or injury resulting from this product detaching from the machining equipments, bristles breaking off, workpieces breaking, etc.
- Do not use the product while exceeding the maximum rotational speed, depth of cut, or brush projection, as there is the risk of operator loss of sight or injury resulting from this product detaching from the machining equipment, bristles breaking off, workpieces breaking, etc.
- Use the XEBEC Brush Surface suitable to the applicable brush diameter, and use the bush matching the shank diameter of the XEBEC Brush Surface. There is the risk of operator loss of sight or injury resulting from this product detaching from the machining equipment, parts breaking, etc., if a tool or bush not suitable to the appropriate shank diameter is used.
- When chucking, slide the sleeve shank of the XEBEC Brush Surface all the way to the end of the tool holding tube of this product or bush (the sleeve flange end should directly contact the end of the tool holding tube or the bush). Using the product in ways inconsistent with the methods described in this manual presents a risk of operator loss of sight or injury resulting from this product detaching from the machining equipment, parts breaking, etc.
- Do not press the floating function in further than the permissible operating range (6 mm). Using the product in a way that is not consistent with the methods of this manual presents a risk of operator loss of sight or injury resulting from this product detaching from the machining equipment, parts breaking, etc.

NOTICE

As a result of the above, there is also the risk of damage to machines, jigs, and workpieces.

Operator Safety Protection

⚠ Use of protective equipment

Be sure to wear personal protective gear including goggles, masks, gloves, and earmuffs. Wear clothing with long sleeves or other clothing that does not expose the skin, and fasten the cuffs and hems tightly.

⚠ Attention to the work area

- Install an enclosure so that persons other than the operator do not enter the work area, and ensure that all persons, if any, in the work area are wearing protective equipment.
- Keep the floor of the work area clean at all times to prevent the risk of slipping or tripping on dust, cutting particles, oil, water, or other substance.
- There is the risk of fire caused by heating, sparks, or other factor resulting from use of the product. Do not use the product close to a flammable liquid or in an explosive atmosphere.
Also be sure to enact fire prevention measures.

⚠ Precaution regarding cutting particles

Fragments, cutting particles, and other substances generated during work will be scattered into the surrounding area. Be sure to use a dust collector or other means to collect them.

Pre-Work Check

Perform test operation for 1 minute or more before starting work, and for 3 minutes or more after the machine tool or product was changed, and check that there is no looseness, vibration, or other abnormality of the machine and the part where the product is installed.

Precautions for Use

- Ensure there are no loose screws before use.
- Do not use FH-ST20-60 or FH-ST20-100 with the internal load adjusting screw 1 loose. This can make sliding performance worse.

Installation onto a machining center or other machine

⚠ WARNING: When chucking, slide the shank onto the chuck of the machining equipment securely all the way to the base.

If not inserted all the way to the base when chucked, vibration during machining may cause this product to fall from the machining equipment.

There is the risk that this may cause operator loss of sight or injury.

- When installing, use a chuck that is correct for the shank diameter. Furthermore, when using a side-lock type mechanism to fix FH-ST20-60 or FH-ST20-100 to the machining equipment, tighten the set screws on the flat parts of the floating holder shank.
- Install and use on machining equipment that can control the rotational speed.
- Do not use through-spindle coolant. If coolant gets inside the holder, the floating function may not work properly.
- When using on a horizontal machining center, the floating function may not work if the spring load is low. Make sure you perform an operational check before use.
- You cannot use the product on machining paths with intermittent sections where the XEBEC Brush Surface may fall or where there are protrusions where the floating function cannot work.
- When the product is used with precision machining equipment, there is the risk that cutting particles may have an adverse effect on the equipment sliding parts. Be sure to properly collect cutting particles and wash thoroughly.

When wet machining

Do not aim coolant directly at the floating holder. If dust or coolant gets into the holder, the floating function may not work properly.

When dry machining

Use a dust collector to collect the dust that is generated by machining. If dust gets into the holder, the floating function may not work properly.



XEBEC Floating Holder Instruction Manual (FH-ST20-60, FH-ST20-100)

Specifications

Dimensions

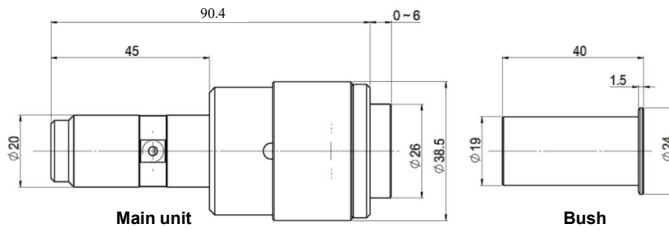

Tool specifications

Product code	Target brush diameter (mm)	Bush	Diameter of sleeve shank (mm)	Maximum rotational speed (min ⁻¹)	Floating stroke (mm)
FH-ST20-60	φ60	XBS1912	φ12	2000*	6
FH-ST20-100	φ100	XBS1916	φ16	1200*	6

The maximum rotational speed is according to the XEBEC Brush Surface Instruction Manual. Set the optimum rotational speed.

* The maximum rotational speed for this product as a stand-alone unit is 5,000min⁻¹.

Spring specifications

	Spring load (N)		Position of load adjusting screw
	0mm stroke	6mm stroke	
Standard floating load	Approx. 2	Approx. 6	Load adjusting screw 2 is at the end of the shaft
High floating load	Approx. 6	Approx. 10	Load adjusting screw 2 is at the back of the shaft

Fitting the brush

- When fitting the bush, align the slider screw holes with the bush holes, push the bush all the way in, then secure the set screws.
 - To fit the XEBEC Brush Surface, slide the shank all the way to the end of the tool holding tube, then firmly tighten the shank-fastening screws.
- * Refer to the below "Maintenance" section for the locations of the parts.

Effective use

The following describes effective ways to use the tool.

- ① Introduce the brush from above the workpiece while it is not in motion.
- ② Cut to the set value and compress the spring.
- ③ After compressing the spring, rotate the brush and start feeding.
- ④ When machining is completed, stop rotating the brush and stop feeding.
- ⑤ Return the brush above the workpiece.

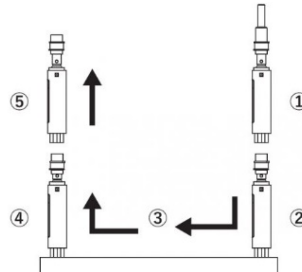

Maintenance

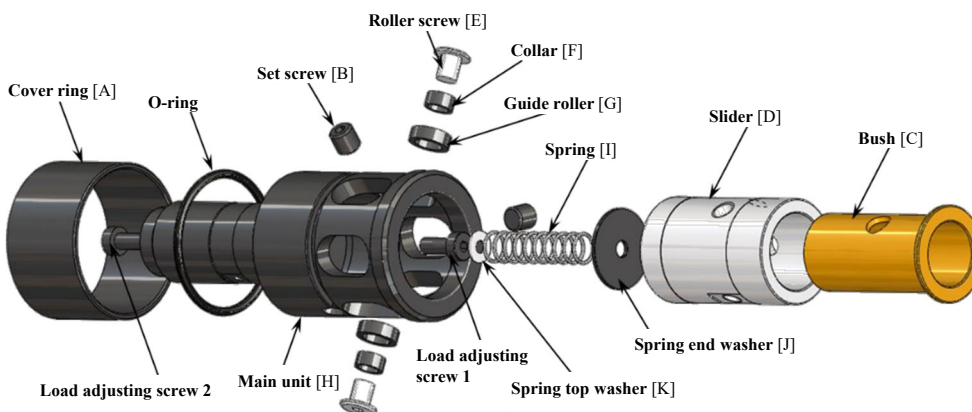

- ① Remove the cover ring [A].
- ② Remove the set screws [B] from 2 locations.
- ③ Remove the bush [C] from the slider [D].
- ④ Remove the roller screws [E], the collars [F], and the guide rollers [G] from 2 locations.
- ⑤ Remove the slider [D] from the main unit [H].
- ⑥ Remove the spring end washer [J], spring [I], and spring top washer [K] from the main unit.
- ⑦ Remove any dirt such as dust, etc., by washing removed components.
- ⑧ Apply grease sparingly to the outer circumference of the slider [D] and the inner circumference of the main unit [H] (Too much grease may influence movement of the slider at low loads.)
 - If there is roughness on the outer circumference of the slider and the inner circumference of the main unit due to friction, use #5000 or equivalent abrasive film to remove the roughness.
 - Recommended grease: Lithium soap grease (NLGI no.2) F
- ⑨ Install the spring washer [J] [K], spring [I], and slider [D] into the main unit [H], then install the roller screws [E], collars [F], and guide rollers [G] (2 locations).
- ⑩ Install the bush [C] into the slider [D] and set the set screws [B].
 - Before installing the bush, confirm that the positions of the screw holes on the slider (2 locations) and the holes on the bush (2 locations) match. If the screws are tightened in a state where these are not matching, the bush might be pushed out of shape and no longer be able to be used.

How to adjust the floating load

For a standard floating load

- ① Loosen load adjusting screw 2.
- ② Tighten load adjusting screw 1.
- ③ Tighten load adjusting screw 2.

Stroke: 0 mm

Position of load adjusting screw ①

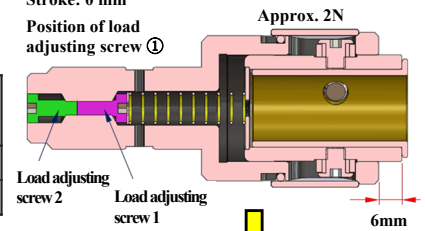

Stroke: 6mm

Position of load adjusting screw ①

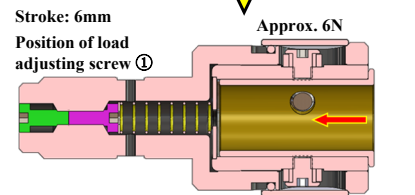

For a high floating load

- ① Loosen load adjusting screw 1.
- ② Tighten load adjusting screw 2.
- ③ Tighten load adjusting screw 1.

Stroke: 0 mm

Position of load adjusting screw ②

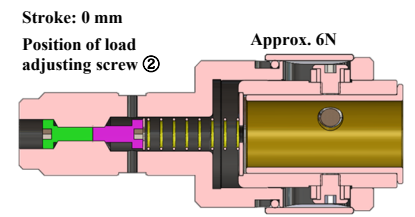

Stroke: 6mm

Position of load adjusting screw ②

